



## Hi-T MAGAlert Non-intrusive Pig Signaller

The Hi-T MAGAlert is a robust non-intrusive magnetic pig signaller used to detect, signal and log the passage of magnetic pigs at critical points along a pipeline. The Hi-T MAGAlert can be used for both offshore and onshore installations.

The Hi-T MAGAlert is ATEX compliant and housed within a fully certified aluminium or 316 stainless steel explosion proof housing suitable for use in Zone 1, Zone 2 group IIA, IIB and H2 Areas.

The Hi-T MAGAlert can log up to 100 events with time and date. Logged events can be viewed on a 70mm (2.7") high visibility display incorporated into the unit.

Pig passages can also be signalled as they occur with ultra-bright LEDs which are incorporated into the unit and are visible from up to 100m. Prior to clearing the history of events it is possible to connect the Hi-T MAGAlert signaller to a PC and download all stored data.



The Hi-T MAGAlert is very quickly and easily attached to a pipeline using ratchet straps or stainless steel bands.

### Detection Principle

The Hi-T MAGAlert incorporates a magnetic sensor which detects changes in the magnetic field (Gauss level). Consequently, pigs must be fitted with rare earth magnets (neodymium iron boron) around the pig body. Detection speed ranges from 0.1 to more than 10 m/s.

The window of detection, typically 0.2m either side of the Hi-T MAGAlert sensor, varies depending upon the pipeline diameter and wall thickness.

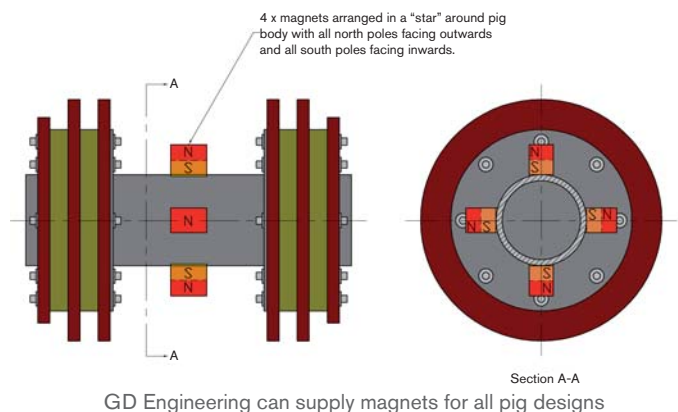

## User-Friendly Display Menu / Operator Interface

All Hi-T MAGAlert sensor functions are very easily accessed using a single external control switch on top of the main housing. Combined with the high visibility display menu this allows operators to quickly cycle through the menu options to review logged events and set-up sensor parameters.

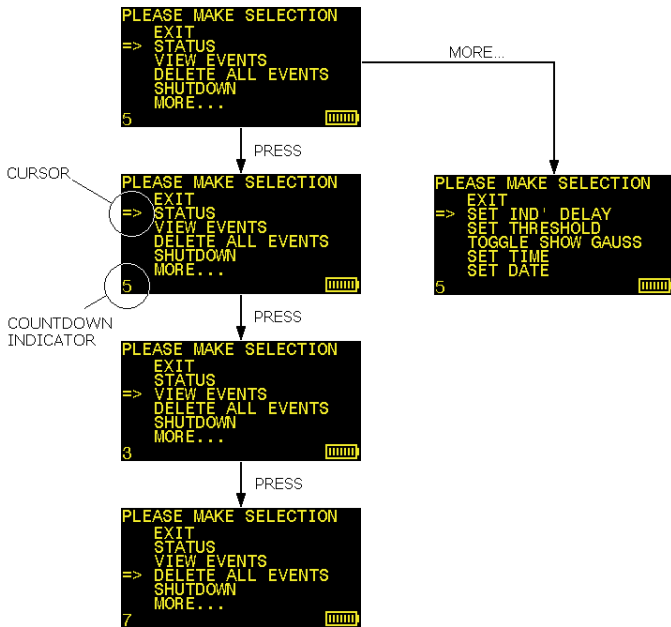

## Unique Modular Design

The Hi-T MAGAlert is a completely modular device that can be very easily adapted to suit a wide variety of installations and interface options. The standard unit incorporates a 9V DC internal battery pack and can be operated completely independently. Alternatively, a 24V DC external power supply can be connected via the single M20 x 1.5 Exd Cable Gland.

## Interface Options

The magnetic sensor can be detached from the main housing using an extension cable to allow the Hi-T MAGAlert to be used on buried pipelines, or in areas where there is limited access.

For remote monitoring the Hi-T MAGAlert can provide DPDT Relay outputs.

The Hi-T MAGAlert can also provide RS232 output through an SWA (Steel Wire Armoured) cable or a suitable EEx e junction box to a control console in a non-hazardous area.

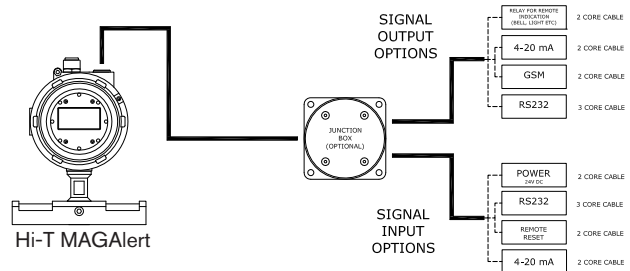

## Optional GSM Alarm Interface

An optional GSM Alarm Interface allows the Hi-T MAGAlert sensor to send a "Pig Detected" message to a maximum of 4 mobile phones. This optional feature allows more freedom for pipeline operators and avoids the requirement and associated costs for having operators mobilised on site.

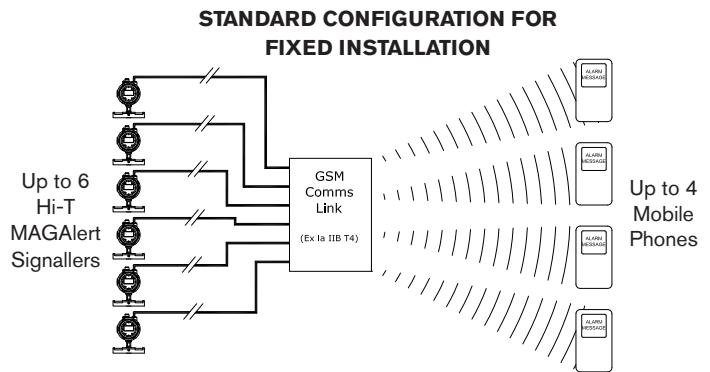

# SPX®

## FLOW CONTROL

Your local contact:



SPX Flow Control  
 Retford Road  
 Worksoy  
 Nottinghamshire S80 2PY  
 Phone: +44 (0) 1909 482323 Fax: +44 (0) 1909 477902  
 E-mail: gd@spx.com



For more information about our worldwide locations, approvals, certifications, and local representatives, please visit [www.spxpe.com](http://www.spxpe.com).

SPX Corporation reserves the right to incorporate our latest design and material changes without notice or obligation. Design features, materials of construction and dimensional data, as described in this bulletin, are provided for your information only and should not be relied upon unless confirmed in writing. Certified drawings are available upon request.